

Return-Temperature Control Valve

**BW 31**

**BW 31A**

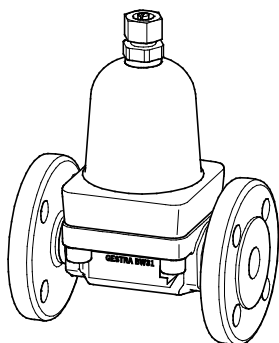
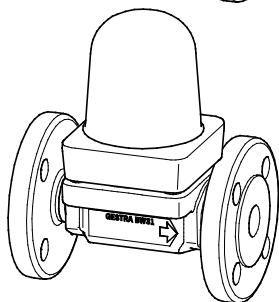
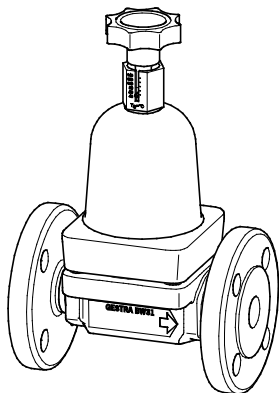

# Contents

|  |           |
|--|-----------|
| <b>Preface.....</b>  | <b>3</b>  |
| Availability.....  | 3         |
| Text layout.....   | 3         |
| <b>Safety.....</b>   | <b>3</b>  |
| Usage for the intended purpose and obvious misuse or abuse.....        | 3         |
| Basic safety notes.....  | 4         |
| Typographic features of safety notes.....                              | 5         |
| <b>Description.....</b>  | <b>5</b>  |
| Scope of supply and equipment specification.....                       | 5         |
| Purpose and function.....  | 8         |
| <b>Storing and transporting the equipment.....</b>                     | <b>8</b>  |
| Storing the equipment.....   | 8         |
| Transporting the equipment.....  | 9         |
| <b>Mounting and connecting the equipment.....</b>                      | <b>9</b>  |
| Preparing installation.....  | 9         |
| Connecting the equipment.....  | 9         |
| <b>Adjusting the closing temperature.....</b>                          | <b>10</b> |
| Adjusting the closing temperature via external setting device.....     | 10        |
| Adjusting the closing temperature without external setting device..... | 12        |
| <b>After operation.....</b>  | <b>17</b> |
| Removing external dirt deposits.....                                   | 17        |
| Purging equipment.....   | 17        |
| Maintaining equipment.....   | 19        |
| Servicing equipment.....   | 19        |
| <b>Troubleshooting.....</b>  | <b>26</b> |
| <b>Putting equipment out of operation.....</b>                         | <b>27</b> |
| Removing harmful substances.....                                       | 27        |
| Removing equipment.....  | 27        |
| Re-using equipment after storage.....                                  | 28        |
| Disposing of equipment.....  | 28        |
| <b>Technical data.....</b>   | <b>29</b> |
| Dimensions and weights.....  | 29        |
| Pressure & temperature ratings.....                                    | 30        |
| Closing temperatures.....  | 30        |
| <b>Manufacturer's Declaration.....</b>                                 | <b>31</b> |

## Preface

This installation & operating manual will help you use the return-temperature control valve KALORIMAT BW 31/BW 31A (referred to as "equipment" in this document) safely and efficiently for its intended purpose.

This installation & operating manual is intended for anyone commissioning, using, operating, servicing, cleaning or disposing of this equipment and, in particular, for professional after-sales service technicians, qualified personnel and authorised and trained staff.

All of these persons must read and understand the content of this installation & operating manual.

Following the instructions given in this installation & operating manual helps avoiding danger and increases the reliability and service life of the equipment. Please note that in addition to the instructions given in this installation & operating manual you must also observe all locally applicable rules and regulations concerning the prevention of accidents as well as approved safety guidelines for good professional practice.

## Availability

Keep this installation & operating manual together with the plant documentation for future reference. Make sure that this installation & operating manual is available to the operator.

The installation & operating manual is part of the equipment. Please hand over this installation & operating manual when selling the equipment or passing it on.

## Text layout

Certain text elements of this installation & operating manual feature a specific typographic design. You can easily distinguish the following text elements:

Standard text

*Cross-reference*

- ▶ Listing
  - ▶ Sub-items in listings
- Steps for action.



Here you will find additional useful information and tips serving to assist you in using the equipment to its fullest potential.

## Safety

### Usage for the intended purpose and obvious misuse or abuse

#### Usage for the intended purpose

The return-temperature control valve KALORIMAT BW 31/BW 31A, hereinafter called "equipment", is installed in fluid return lines. It regulates the return temperature of the fluid as a function of temperature.

- ▶ Equipment type BW 31 is only designed for use with hot water.
- ▶ Equipment type BW 31A is only designed for use with hot oil.

Correct use includes compliance with the instructions given in this installation & operating manual, in particular obedience to all safety instructions.

#### Obvious misuse or abuse

Any other use of the equipment is considered to be improper.

In particular the use as shut-off valve for the return line is not permitted.

Note that the equipment is also used incorrectly if the body material of the equipment is not suitable for the fluid.

## Basic safety notes

### Risk of severe injuries

- ▶ The equipment is under pressure and hot during operation. Before carrying out any work on the equipment make sure that the following requirements are met:
  - ▶ The pipes must be depressurized (0 bar).
  - ▶ The fluid must be completely removed from the pipes and the equipment.
  - ▶ During work on the equipment the installation must be switched off and protected against unauthorised or unintended activation.
  - ▶ The pipes and the equipment must have cooled down to room temperature (approx. 20 °C).
- ▶ If the equipment is used in contaminated areas there is a risk of severe injuries or death caused by harmful substances in or on the equipment. Before working on the equipment make sure that it is completely decontaminated. Always wear the protective clothing prescribed for contaminated areas when working on the equipment.
- ▶ The equipment must only be used with fluids that do not attack the body material and the gaskets and sealings. Otherwise leaks may occur and hot or toxic fluid could escape.
- ▶ The equipment and its component parts must only be mounted or removed by qualified personnel. A qualified person must be acquainted with and experienced in the following:
  - ▶ Making pipe connections.
  - ▶ Working with dangerous (contaminated, hot or pressurized) fluids.

### Risk of minor injuries

- ▶ Sharp edges on internals present the danger of cuts to hands. Always wear industrial gloves when servicing the equipment.
- ▶ If the support of the equipment during installation is insufficient the equipment might fall down, thereby causing bruises or injuries. Make sure the equipment is safely held in place during installation and cannot fall down. Wear protective safety footwear.

### Risk of property damage or malfunctions

- ▶ Malfunctions will occur if the equipment is installed in a wrong position or with the flow arrow pointing in the opposite direction of the fluid flow. This may result in damage to the equipment or the installation. Make sure that the flow arrow on the equipment body matches the indicated direction of the fluid flow in the pipe.
- ▶ If the body material is unsuitable for the fluid, increased wear may occur and fluid may escape. Before mounting the equipment make sure that the body material is suitable for the fluid used in your installation.
- ▶ Incorrect temperature settings can affect the proper performance of the installation. Consequently, parts of the installation could be damaged.
  - ▶ Make sure that only qualified and trained personnel change the closing temperature setting.
  - ▶ Do not adjust a closing temperature that is below the factory setting. For more information on default factory settings see chapter *"Adjusting the closing temperature"* on page 10.
- ▶ An inclined installation position can lead to increased wear on the equipment. Please contact the manufacturer if the equipment cannot be installed with the cover pointing vertically upwards or hanging downwards.

## Typographic features of safety notes

### Danger note

---



#### **DANGER**

Notes with the heading DANGER warn against imminent dangerous situations that can lead to death or serious injuries.

---

---



#### **WARNING**

Notes with the heading WARNING warn against possibly dangerous situations that could lead to death or serious injuries.

---

---



#### **CAUTION**

Notes with the heading CAUTION warn against dangerous situations that could lead to minor or moderate injuries.

---

### Information on environmental and property damage

---

#### ***Attention!***

This note warns against situations that may lead to environmental and/or property damage.

---

## Description

### Scope of supply and equipment specification

#### Scope of supply

Our equipment is delivered packed and ready for assembly.

#### Equipment specification

The equipment consists of the following main components:

- ▶ Body,
- ▶ Cover and
- ▶ Regulator.

For the designation of the individual component parts please refer to the following pages.

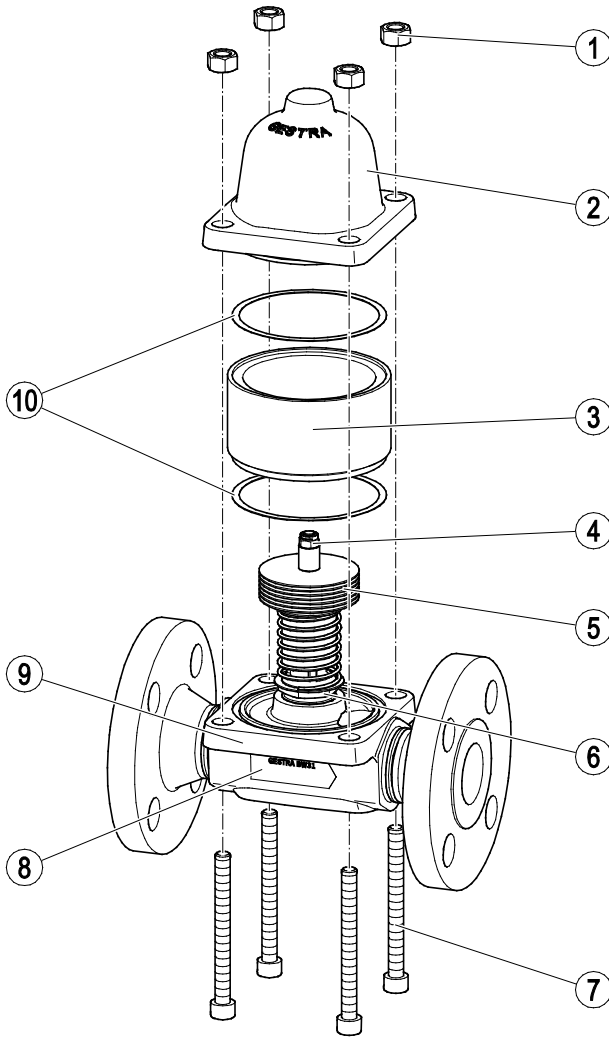

| No. | Designation                 |
|-----|-----------------------------|
| 1   | Nuts (only DN40)            |
| 2   | Cover                       |
| 3   | Distance sleeve (only DN40) |
| 4   | Adjustment nut              |
| 5   | Bimetallic regulator plates |

| No. | Designation                          |
|-----|--------------------------------------|
| 6   | Thermovit regulator                  |
| 7   | Socket-head bolts                    |
| 8   | Name plate with flow direction arrow |
| 9   | Body                                 |
| 10  | Gaskets (2 for DN40)                 |

An external setting device is available as optional extra. This external setting device allows you to change the closing temperature during operation

without having to remove the cover. There are different external setting devices depending on the equipment type.

## External setting device for BW 31

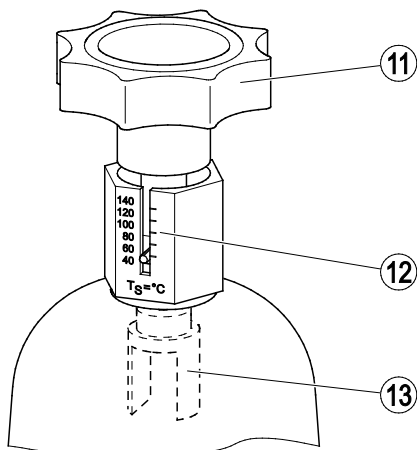

| No. | Designation             |
|-----|-------------------------|
| 11  | Star grip knob          |
| 12  | Temperature scale       |
| 13  | Forked adjustment piece |

## External setting device for BW 31A

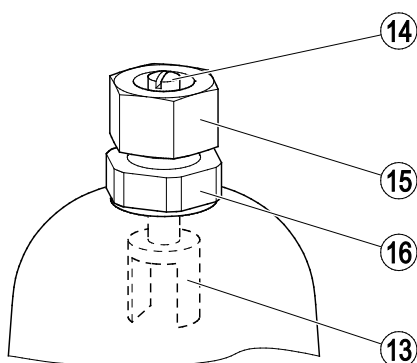

| No. | Designation             |
|-----|-------------------------|
| 13  | Forked adjustment piece |
| 14  | Adjustment stem         |
| 15  | Locknut                 |
| 16  | Twin nipple             |

**i** Equipment with an external setting device is fitted with a square nut instead of an adjustment nut.

### End connections

The equipment is available with the following end connections:

- ▶ Butt-weld ends
- ▶ Butt-weld ends via transition pieces
- ▶ Socket-weld ends
- ▶ Flanges
- ▶ Screwed sockets

### Name plate

The following items are indicated on the name plate:

- ▶ Type designation
- ▶ Nominal size
- ▶ Nominal pressure
- ▶ Differential pressure
- ▶ Temperature
- ▶ Flow arrow

**i** The name plate is pointed on one side. This serves as an additional indication of the flow direction.

In addition, you will find the following indications on the body or cover:

- ▶ Material specification
- ▶ Factory set closing temperature

### Application of European Directives

#### Pressure Equipment Directive

The equipment conforms to this directive (see "Manufacturer's Declaration" section) and can be used for the following media:

#### BW 31

- ▶ Fluids of group 2

#### BW 31A

- ▶ Fluids of group 1
- ▶ Fluids of group 2

## ATEX Directive

The equipment does not have its own potential ignition source and is not subject to this directive (see "Manufacturer's Declaration" section).

When installed, static electricity may arise between the equipment and the connected system.

When used in potentially explosive atmospheres, the plant manufacturer or plant operator is responsible for discharging or preventing possible static charge.

If it is possible for medium to escape, e.g. through actuating mechanisms or leaks in threaded joints, the plant manufacturer or plant operator must take this into consideration when dividing the area into zones.

## Purpose and function

### Purpose

The equipment regulates and controls distribution processes in industrial heating systems. As the fluid temperature falls the equipment increases the fluid flow in the return line. The fluid will only flow off if its temperature is below the closing temperature. Consequently, the flowrate, pressure and temperature of the fluid are maintained at a fairly constant level and heat loss is minimized.

The closing temperature is set at our factory. You can change these default settings within the adjustable temperature range. For more information see chapter "*Adjusting the closing temperature*" on page 10.

### Function

The equipment regulates the flow of the fluid by means of a Thermovit regulator and the force of a spring.

As the fluid temperature falls the orifice opens. More fluid can flow through. As the fluid temperature rises the orifice of the Thermovit regulator closes. Less fluid can flow through.

The orifice always remains slightly open, thereby allowing a small flowrate ("bleed flow") to pass through. The Thermovit regulator is therefore always surrounded by fluid and can react instantaneously if the temperature changes.

## Storing and transporting the equipment

### Attention!

Equipment can be damaged if stored or transported improperly.

- Close all openings with the sealing plugs or covers supplied with the equipment or use similar sealing covers.
- Protect the equipment against moisture and corrosive atmospheres.
- Please contact the manufacturer if the specified transport and/or storage requirements cannot be met.

## Storing the equipment

Please observe the following items when storing the equipment:

- Do not store the equipment for more than 12 months.
- Use the supplied sealing plugs or other suitable seal caps in order to seal off all openings and make the equipment watertight.
- Protect the sealing surfaces and contact areas against mechanical damage.
- Protect the equipment and all components against hard shocks and impacts.
- Store the equipment only in closed rooms that meet the following environmental conditions:
  - Air humidity below 50 %, not condensing
  - Indoor air: clean, salt-free and non-corrosive
  - Temperature 5–40 °C.
- Make sure that all these requirements are always met when storing the equipment.
- Please contact the manufacturer if you cannot comply with the recommended storage conditions.



## Transporting the equipment

- Meet the requirements for storage also when transporting the equipment.
- Prior to transport seal off connections with sealing plugs.

 If you do not have the sealing plugs supplied with the equipment use appropriate seal caps to seal off the connections.

- For short distances (only a few metres) you can transport the equipment unpacked.
- When transporting the equipment over larger distances use the original packaging.
- If you do not have the original packaging use a box that protects the equipment adequately against corrosion and physical damage.

 For a short period of time the equipment may be transported even if the temperature is below 0 °C, provided that the equipment is completely empty and dry.

## Mounting and connecting the equipment

### Preparing installation

- Take the equipment out of the transport packaging.
- Check the equipment for transport damage.
- Contact the manufacturer if you detect any kind of shipping damage.

When supplied by the factory, the connections are sealed off with sealing plugs.

- Remove sealing plugs before mounting the equipment.
- Keep the sealing plugs for further use.



## DANGER

Personnel working on pipes are exposed to safety risks and may suffer severe injuries, burns, poisoning or even loss of life.

- Make sure that no hot or hazardous fluid is in the equipment or the pipes.
- Make sure that the installation is switched off and protected against unauthorised or unintended activation.
- Make sure that the equipment and the pipes have cooled down to room temperatures.

- 
- Drain pipes until they are empty.
  - Switch the installation off and protect it against unauthorised or unintended re-activation.

## Connecting the equipment



## DANGER

Incorrectly connected equipment can cause fatal accidents or severe injuries.

- Make sure that only qualified skilled personnel connect the equipment to pipes.
- Make sure that the flow arrow on the equipment body matches the direction of flow in the pipe.

---

Specialist personnel must be highly qualified and fully experienced in making pipe connections for the respective type of end connection.

---

### **Attention!**

Equipment will be damaged if the end connections are undersized.

- Make sure that the connections are strong and rigid enough to support the weight of the equipment and to withstand the forces that occur during operation.

- 
- The equipment should be fitted in a horizontal pipe with the cover in a vertical position.



In exceptional cases the equipment can also be installed with the cover in an inclined plane.

---

### **Attention!**

An inclined installation position of the cover can affect the performance of the equipment and increase wear on the Thermovit regulator.

- Please contact the manufacturer if an installation with the cover in a vertical position is not possible in your plant.

- 
- Mount the equipment in the desired installation position.
  - Make sure that the equipment is safely mounted and that all connections are made correctly.



To remove residues from the pipes and the equipment after installation purge the pipes with the fluid to be used. For more information see chapter *"Purging equipment"* on page 17.

## **Adjusting the closing temperature**

When delivered, the equipment features a factory-set closing temperature in accordance with the design data.

---

### **Attention!**

Risk of malfunctions or damage due to incorrect setting of Thermovit regulator.

- Make sure that only qualified personnel change the closing temperature setting.
- Do not adjust a closing temperature that is below the factory-set closing temperature.

---

Note that closing temperatures below the factory setting may damage the Thermovit regulator.

- If you want to set a lower closing temperature you have to use different equipment.



To re-set the factory setting of the closing temperature use the set value indicated in the table in chapter *"Adjusting the closing temperating without external setting device"*.

## **Adjusting the closing temperature via external setting device**

The external setting device enables you to change the closing temperature without having to remove the cover.

You can therefore change the closing temperature setting also during operation.

There are different procedures for BW 31 and BW 31A.

### **Adjusting the closing temperature for BW 31**

Use the star grip knob of the external setting device to adjust the desired set value. The current closing temperature is indicated by the scale. When the equipment is delivered the closing temperature is set to the lowest value.

### **Attention!**

Risk of malfunctions or damage due to incorrect setting of Thermovit regulator.

- Make sure that only qualified personnel change the closing temperature setting.
- Do not adjust a closing temperature that is below the factory-set closing temperature.

- To lower the closing temperature turn the star grip knob clockwise.
- To raise the closing temperature turn the star grip knob anticlockwise.
- To check the setting measure the return temperature of the fluid downstream of the equipment.
- Repeat the setting procedure if the return temperature does not meet the set value.

### **Adjusting the closing temperature for BW 31A**

The closing temperature is set via the slide lift. When the equipment is delivered, the following temperature settings as a function of nominal size are possible:

#### **Factory setting for BW 31A with external setting device**

| <b>Nominal size</b> | <b>Closing temperature [°C]</b> | <b>Set value X [mm]</b> | <b>Lift Y [mm]</b> |
|---------------------|---------------------------------|-------------------------|--------------------|
| DN15                | 90                              | 27.0                    | 4.6                |
| DN20, DN25          | 70                              | 27.6                    | 4.0                |
| DN40                | 70                              | 48.4                    | 6.6                |

These factory settings are calculated for ambient temperatures of 18 – 21 °C.

To change the settings proceed as follows:



### **WARNING**

Injuries such as burns or poisoning may occur if fluid escapes through the external setting device.

- Make sure that the twin nipple of the external setting device is fixed and cannot work loose.
- Use an open-end spanner (US: wrench) to secure the twin nipple (16) against inadvertent misadjustment.
- To loosen the locknut (15) turn it anticlockwise.
- To raise the closing temperature turn the adjustment stem (14) anticlockwise.

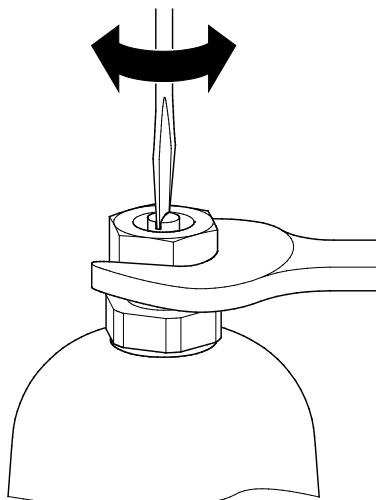

### **Attention!**

Risk of malfunctions or damage due to incorrect setting of Thermovit regulator.

- Make sure that only qualified personnel change the closing temperature setting.
- Do not adjust a closing temperature that is below the factory-set closing temperature.

- To lower the closing temperature turn the adjustment stem (14) clockwise.

The following table indicates the closing temperature that will be set by giving the adjustment stem a certain number of full turns. Note that the indicated values are based on the factory setting.

| Number of turns | DN15 | DN20<br>DN25 | DN40 |
|-----------------|------|--------------|------|
| 1               | 104  | 83           | 80   |
| 2               | 120  | 95           | 90   |
| 3               | 137  | 109          | 102  |
| 4               | 156  | 123          | 116  |
| 5               | 180  | 137          | 136  |
| 6               | 210  | 158          | 165  |
| 7               | 260  | 180          | 196  |
| 8               | –    | 210          | 237  |
| 9               | –    | 255          | –    |

To set the max. closing temperature of 280 °C turn the adjustment stem as often as indicated in the following table.

| Nominal size | Number of full turns |
|--------------|----------------------|
| DN15         | 7.2                  |
| DN20, DN25   | 9.4                  |
| DN40         | 8.7                  |

### **Attention!**

Incorrect setting if the adjustment stem is turned inadvertently when tightening the locknut.

- Use a screwdriver to secure the adjustment stem against turning when tightening the locknut.

- To secure the adjustment stem (14) against turning fasten locknut (15) hand-tight, while securing the adjustment stem with a screwdriver.
- To check the setting measure the return temperature of the fluid downstream of the equipment.

- Repeat the setting procedure if the return temperature does not meet the set value.

## **Adjusting the closing temperating without external setting device**

Remove cover to change the closing temperature without using the external setting device. When delivered, the equipment features the closing temperature setting specified in the order.

There is a set value for each closing temperature. The set value X is measured between the upper and the lower spring plate.

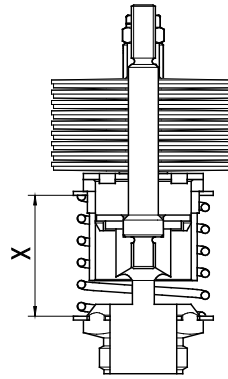

Equipment of size DN 15 does not have a lower spring plate. With this equipment you have to measure the set value between the upper spring plate and the top edge of the hexagon part.



## DANGER

Personnel working on pipes are exposed to safety risks and may suffer severe injuries, burns, poisoning or even loss of life.

- Make sure that no hot or hazardous fluid is in the equipment or the pipes.
- Make sure that the installation is switched off and protected against unauthorised or unintended activation.
- Make sure that the equipment and the pipes have cooled down to room temperatures.

- Remove the cover as described on page 18.

## Attention!

Risk of malfunctions or damage due to incorrect setting of Thermovit regulator.

- Make sure that only qualified personnel change the closing temperature setting.
- Do not adjust a closing temperature that is below the factory-set closing temperature.

## Ascertaining set value

The set value depends on the type of equipment and the desired closing temperature.

- Refer to the following tables for the required set value.

## Ascertaining the set value for BW 31

The number of plate pairs used in the Thermovit regulator depends on the required closing temperature.

| Closing temperature | Number of plate pairs |
|---------------------|-----------------------|
| <b>DN15</b>         |                       |
| 20–140 °C           | 7                     |
| 145–160 °C          | 6                     |
| <b>DN20, DN25</b>   |                       |
| 20–115 °C           | 9                     |
| 120–160 °C          | 8                     |
| <b>DN40</b>         |                       |
| 20–130 °C           | 7                     |
| 135–160 °C          | 6                     |

## Attention!

Risk of malfunctions or damage due to incorrect setting of Thermovit regulator.

Only the correct number of plate pairs ensures that the set value yields the correct closing temperature.

- Before adjusting the set value make sure that the correct number of plate pairs is used.
- If necessary mount a Thermovit regulator with the correct number of plate pairs.

| Closing temperature<br>[°C] | Set value [mm] |               |      |
|-----------------------------|----------------|---------------|------|
|                             | DN15           | DN20,<br>DN25 | DN40 |
| 20                          | 22.4           | 23.6          | 41.8 |
| 25                          | 22.8           | 24.2          | 42.7 |
| 30                          | 23.2           | 24.8          | 43.6 |
| 35                          | 23.6           | 25.3          | 44.4 |
| 40                          | 24.0           | 25.8          | 45.2 |
| 45                          | 24.4           | 26.4          | 46.0 |
| 50                          | 24.8           | 26.9          | 46.8 |
| 55                          | 25.2           | 27.4          | 47.6 |
| 60                          | 25.6           | 28.0          | 48.5 |
| 65                          | 26.0           | 28.5          | 49.3 |
| 70                          | 26.4           | 29.0          | 50.1 |
| 75                          | 26.7           | 29.5          | 50.9 |
| 80                          | 27.1           | 30.1          | 51.7 |
| 85                          | 27.5           | 30.7          | 52.4 |
| 90                          | 27.9           | 31.3          | 53.0 |
| 95                          | 28.3           | 31.8          | 53.5 |
| 100                         | 28.7           | 32.3          | 54.0 |
| 105                         | 29.0           | 32.8          | 54.4 |
| 110                         | 29.4           | 33.3          | 54.8 |
| 115                         | 29.8           | 33.8          | 55.1 |
| 120                         | 30.2           | 32.7          | 55.5 |
| 125                         | 30.6           | 33.0          | 55.8 |
| 130                         | 30.9           | 33.3          | 56.2 |
| 135                         | 31.2           | 33.6          | 54.5 |
| 140                         | 31.5           | 34.0          | 54.8 |
| 145                         | 30.4           | 34.3          | 55.0 |
| 150                         | 30.7           | 34.6          | 55.3 |
| 155                         | 31.0           | 34.9          | 55.5 |
| 160                         | 31.2           | 35.1          | 55.7 |

The set value is based on ambient temperatures of 18 – 21 °C. If the ambient temperature is higher or lower use the following table to adjust the set value.

| Ambient temperature<br>[°C] | Correction value [mm] |               |      |
|-----------------------------|-----------------------|---------------|------|
|                             | DN15                  | DN20,<br>DN25 | DN40 |
| 9–12                        | +0.75                 | +0.9          | +1.5 |
| 12–15                       | +0.5                  | +0.6          | +1.0 |
| 15–18                       | +0.25                 | +0.3          | +0.5 |
| 18–21                       | 0                     |               |      |
| 21–24                       | -0.25                 | -0,3          | -0.5 |
| 24–27                       | -0.5                  | -0.6          | -1.0 |
| 27–30                       | -0.75                 | -0.9          | -1.5 |



Please contact the manufacturer if the ambient temperature passes outside the indicated temperature range.

## Ascertaining the set value for BW 31A

| Closing temperature<br>[°C] | Set value [mm] |               |      |
|-----------------------------|----------------|---------------|------|
|                             | DN15           | DN20,<br>DN25 | DN40 |
| 20                          | 22.4           | 23.6          | 41.8 |
| 30                          | 23.0           | 24.4          | 43.1 |
| 40                          | 23.6           | 25.2          | 44.4 |
| 50                          | 24.3           | 26.0          | 45.7 |
| 60                          | 25.0           | 26.8          | 47.1 |
| 70                          | 25.7           | 27.6          | 48.4 |
| 80                          | 26.4           | 28.4          | 49.7 |
| 90                          | 27.0           | 29.2          | 50.9 |
| 100                         | 27.7           | 30.0          | 52.0 |
| 110                         | 28.4           | 30.7          | 52.9 |
| 120                         | 29.0           | 31.4          | 53.6 |
| 130                         | 29.6           | 32.1          | 54.2 |
| 140                         | 30.2           | 32.7          | 54.8 |
| 150                         | 30.7           | 33.2          | 55.3 |
| 160                         | 31.2           | 33.7          | 55.7 |
| 170                         | 31.6           | 34.2          | 56.1 |
| 180                         | 32.0           | 34.6          | 56.5 |
| 190                         | 32.4           | 35.0          | 56.9 |
| 200                         | 32.7           | 35.3          | 57.3 |
| 210                         | 33.0           | 35.6          | 57.6 |
| 220                         | 33.2           | 35.8          | 57.9 |
| 230                         | 33.4           | 36.1          | 58.2 |
| 240                         | 33.6           | 36.3          | 58.5 |
| 250                         | 33.8           | 36.5          | 58.7 |
| 260                         | 34.0           | 36.7          | 59.0 |
| 270                         | 34.1           | 36.9          | 59.2 |
| 280                         | 34.2           | 37.0          | 59.3 |

The set value is based on ambient temperatures of 18 – 21 °C. If the ambient temperature is higher or lower use the following table to adjust the set value.

| Ambient temperature<br>[°C] | Correction value [mm] |               |      |
|-----------------------------|-----------------------|---------------|------|
|                             | DN15                  | DN20,<br>DN25 | DN40 |
| 9–12                        | +0.6                  | +0.75         | +1.2 |
| 12–15                       | +0.4                  | +0.5          | +0.8 |
| 15–18                       | +0.2                  | +0.25         | +0.4 |
| 18–21                       | 0                     |               |      |
| 21–24                       | -0.2                  | -0.25         | -0.4 |
| 24–27                       | -0.4                  | -0.5          | -0.8 |
| 27–30                       | -0.6                  | -0.75         | -1.2 |

### Changing set value

#### **Attention!**

Risk of malfunctions or damage due to incorrect setting of Thermovit regulator.

Only the correct number of plate pairs ensures that the set value yields the correct closing temperature.

- Before adjusting the set value make sure that the correct number of plate pairs is used.
- If necessary mount a Thermovit regulator with the correct number of plate pairs.

Use the Thermag nut (4) to adjust the desired set value.

The Thermag nut used in equipment DN 15 to DN 25 is a nut type M6 and in equipment DN 40 a nut M8. It is locked and sealed with Loctite 222.

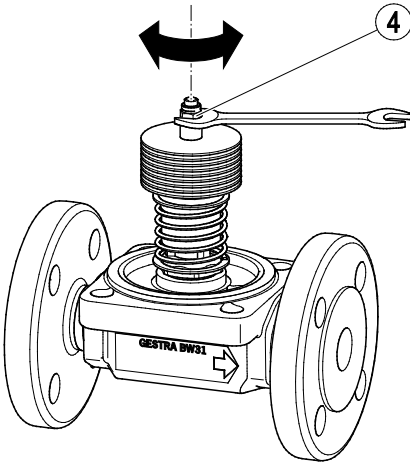

➤ To reduce the set value fasten the Thermag nut.  
The closing temperature is reduced.

➤ To increase the set value loosen the adjustment nut.

The closing temperature is increased.

➤ Use Loctite 222 to lock and seal the Thermag nut against inadvertent misadjustment.

➤ Attach cover to the equipment as described on page 18.

➤ To check the setting measure the return temperature of the fluid downstream of the equipment.

➤ Repeat the setting procedure if the return temperature does not meet the set value.



## After operation

---



### DANGER

If the equipment is used in contaminated areas there is a risk of severe injuries or death caused by harmful substances in or on the equipment.

- Only qualified personnel are allowed to perform work on contaminated equipment.
  - Always wear the protective clothing prescribed for contaminated areas when working on the equipment.
  - Make sure that the equipment is completely decontaminated before carrying out any service work.
  - Follow the pertinent instructions for handling the hazardous substances in question.
- 

## Removing external dirt deposits

- Use fresh water and a cloth to remove dirt and contaminants from the equipment body.

## Purging equipment

Rinse the equipment in order to remove any dirt particles or fluid residues inside the equipment.



When fixing the cover onto the equipment body the gasket will be compressed. As a result the gasket can no longer seal properly if the cover is taken off again. It is therefore essential that you always insert a new gasket whenever you remove and re-attach the cover.

---

## Attention!

Malfunctions due to dirt deposits on Thermovit regulator.

- Remove Thermovit regulator before rinsing the equipment.
- 

To remove the Thermovit regulator proceed as follows:

---



### DANGER

Personnel working on pipes are exposed to safety risks and may suffer severe injuries, burns, poisoning or even loss of life.

- Make sure that no hot or hazardous fluid is in the equipment or the pipes.
  - Make sure that the installation is switched off and protected against unauthorised or unintended activation.
  - Make sure that the equipment and the pipes have cooled down to room temperatures.
-

## Removing cover

The cover of equipment DN 15 to DN 25 is fixed in place by means of four 8 mm socket-head cap screws. The cover of equipment DN 40 is fixed in place by means of four hexagon-head bolts M13 and nuts.

- Slacken the four cover screws or bolts.
- Take the four nuts off the equipment (DN 40).
- Lift the cover off the body.

## Removing Thermovit regulator

The Thermovit regulator is screwed to the body via a hexagon piece A. F. 24 mm (DN 40: A. F. 36 mm).

- Unscrew the Thermovit regulator off the body at the hexagon piece.

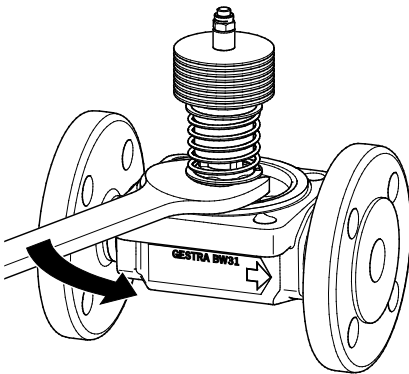

## Mounting cover

### **Attention!**

Equipment may leak if the gasket is damaged.

- It is therefore essential that you always insert a new gasket before re-attaching the cover.
- Make sure that the cover is not tilted or skewed when refitted.

- Fix cover to equipment body.

- Fasten screws / nuts and bolts with the following tightening torque:
  - DN15 to DN25: 35 Nm
  - DN40: 45 Nm

## Purging pipes

### **Attention!**

Equipment may be damaged by unsuitable cleaning fluid.

- Rinse the pipe with the same fluid that is used during normal operation.
  - Make sure that the cleaning fluid does not come into contact with the fluid used during normal operation.
  - Make sure that the cleaning fluid does not damage the equipment material if you use a different fluid for cleaning than the normal operating fluid.
- 
- Switch on the installation and rinse the pipes.
  - Check connections for leaks.
  - After rinsing keep the installation switched on until the pipes are completely empty.
  - Switch the installation off and protect it against unauthorised or unintended re-activation.

## Mounting Thermovit regulator after purging

- Remove the cover as described on page 18.
- 

### ***Attention!***

Malfunctions due to inadvertent misadjustment of Thermovit regulator.

- Make sure that the setting of the Thermovit regulator is not changed when mounting or servicing the equipment.
- 
- Fasten the Thermovit regulator with the following tightening torque:
    - ▶ DN15 to DN25: 90 Nm
    - ▶ DN40: 140 Nm.
  - Attach cover to the equipment as described on page 18.

## Maintaining equipment

The equipment is maintenance-free.

## Servicing equipment

You may exchange the following component parts in case of wear or damage:

- ▶ Thermovit regulator
- ▶ Gasket between cover and body
- ▶ External setting device (if provided)
- ▶ Gasket for external setting device (if provided)

## Spare parts for BW31 without external setting device

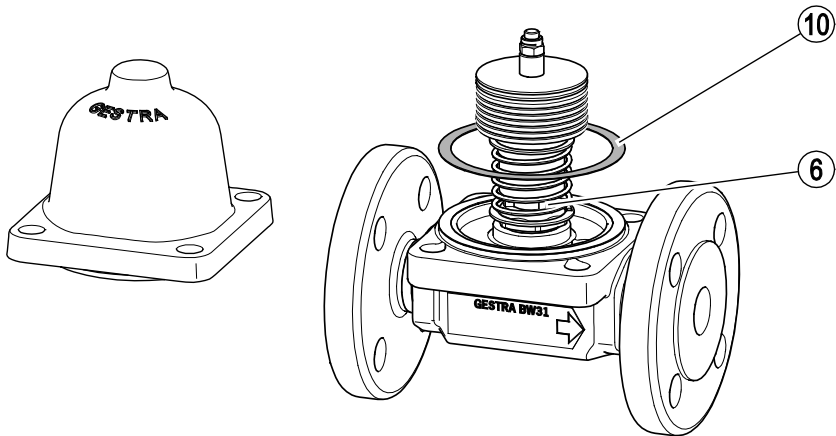

| No. | Designation                   | DN         | Temperature range [°C] | Qty. | Stock code # |
|-----|-------------------------------|------------|------------------------|------|--------------|
| 6   | Thermovit regulator, complete | 15         | 20–90                  | 1    | 184726       |
|     |                               |            | 60–130                 | 1    | 031884       |
|     |                               | 20, 25     | 20–90                  | 1    | 184560       |
|     |                               |            | 40–115                 | 1    | 004339       |
|     |                               | 40         | 20–65                  | 1    | 184544       |
|     |                               |            | 50–110                 | 1    | 004342       |
| 10  | Gasket                        | 15, 20, 25 |                        | 20*  | 560493       |
|     |                               | 40         |                        | 20** | 375699       |

\* one piece required

\*\* two pieces required

## Spare parts for BW31A without external setting device

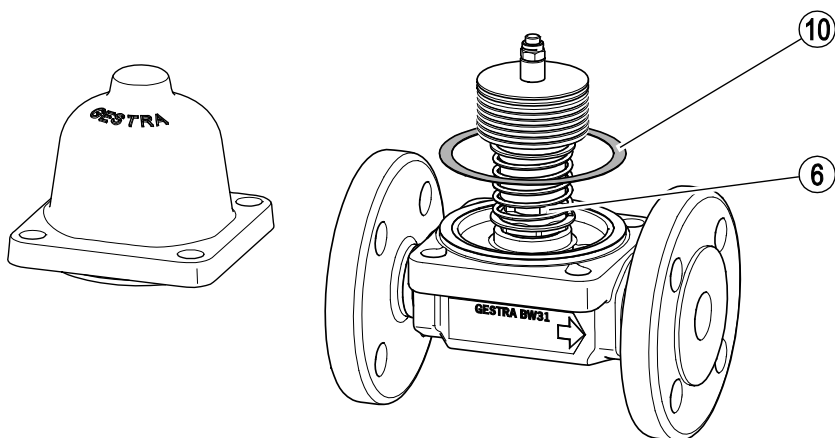

| No. | Designation                    | DN         | Temperature range [°C] | Qty. | Stock code # |
|-----|--------------------------------|------------|------------------------|------|--------------|
| 6   | Thermovolt regulator, complete | 15         | 60–120                 | 1    | 377776       |
|     |                                |            | 120–270                | 1    | 184807       |
|     |                                | 20, 25     | 30–120                 | 1    | 184880       |
|     |                                |            | 100–280                | 1    | 184731       |
|     |                                | 40         | 30–80                  | 1    | 184857       |
|     |                                |            | 100–270                | 1    | 184808       |
| 10  | Gasket                         | 15, 20, 25 |                        | 20*  | 560493       |
|     |                                | 40         |                        | 20** | 375699       |

\* one piece required

\*\* two pieces required

**Spare parts for BW31 with external setting device**

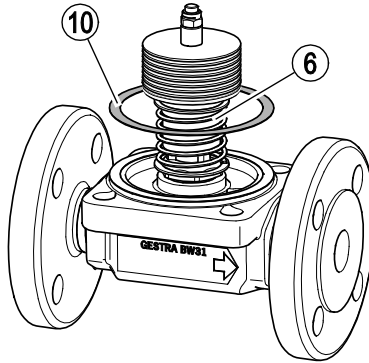
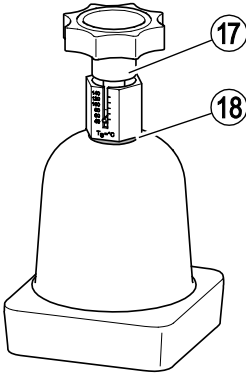

| No. | Designation                        | DN         | Temperature range [°C] | Qty. | Stock code # |
|-----|------------------------------------|------------|------------------------|------|--------------|
| 6   | Thermovit regulator, complete      | 15         | 20–110                 | 1    | 184550       |
|     |                                    |            | 60–130                 | 1    | 031896       |
|     |                                    | 20, 25     | 20–90                  | 1    | 036933       |
|     |                                    |            | 40–115                 | 1    | 004340       |
|     |                                    | 40         | 20–75                  | 1    | 038972       |
|     |                                    |            | 50–110                 | 1    | 004343       |
| 10  | Gasket                             | 15, 20, 25 |                        | 20*  | 560493       |
|     |                                    | 40         |                        | 20** | 375699       |
| 17  | External setting device            | 15         | 20–120                 | 1    | 184899       |
|     |                                    |            | 40–140                 | 1    | 184990       |
|     |                                    | 20, 25     | 20–110                 | 1    | 184753       |
|     |                                    |            | 40–140                 | 1    | 184754       |
|     |                                    | 40         | 20–100                 | 1    | 184756       |
|     | 50–130                             | 1          | 184757                 |      |              |
| 18  | Gasket for external setting device | 15, 20, 25 |                        | 1    | 014934       |
|     |                                    | 40         |                        | 1    | 014935       |

\* one piece required

\*\* two pieces required

## Spare parts for BW31A with external setting device

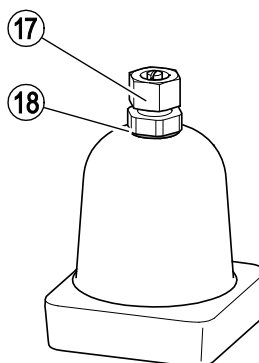
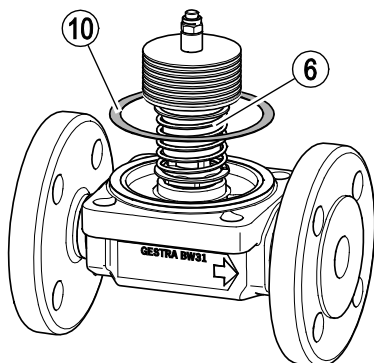

| No. | Designation                        | DN         | Temperature range [°C] | Qty. | Stock code # |
|-----|------------------------------------|------------|------------------------|------|--------------|
| 6   | Thermovit regulator, complete      | 15         | 60–160                 | 1    | 184631       |
|     |                                    |            | 90–270                 | 1    | 004010       |
|     |                                    | 20, 25     | 30–170                 | 1    | 184937       |
|     |                                    |            | 70–270                 | 1    | 004022       |
|     |                                    | 40         | 25–85                  | 1    | 184661       |
|     |                                    |            | 70–270                 | 1    | 004025       |
| 10  | Gasket                             | 15, 20, 25 |                        | 20*  | 560493       |
|     |                                    | 40         |                        | 20** | 375699       |
| 17  | External setting device            | 15         |                        | 1    | 184902       |
|     |                                    | 20, 25     |                        | 1    | 004013       |
|     |                                    | 40         |                        | 1    | 004027       |
| 18  | Gasket for external setting device | 15, 20, 25 |                        | 1    | 014934       |
|     |                                    | 40         |                        | 1    | 014935       |

\* one piece required

\*\* two pieces required

## Exchanging Thermovit regulator

Only the complete Thermovit regulator unit can be exchanged.

- Remove the cover as described on page 18.
- Unscrew the Thermovit regulator off the body as described on page 18.
- Fasten the Thermovit regulator with the tightening torque indicated on page 19.
- ▶ DN15 to DN25: 90 Nm
- ▶ DN40: 140 Nm.
- Attach cover to the equipment as described on page 18.

## Exchanging gasket

- Remove the cover as described on page 18.
- Remove the gasket from the body.

### **Attention!**

Dirt deposits on gasket seating surfaces may result in leaking of the equipment.

- Clean seating surfaces before inserting a new gasket.

- Clean gasket seating surfaces.
- Insert a new gasket in the body.
- Attach cover to the equipment as described on page 18.

## Exchanging external setting device

To exchange the external setting device proceed as follows:

### **Attention!**

Equipment may be damaged if screwdriver is applied to the scale.

Using a screwdriver may cause damage to the scale of equipment type BW 31.

- Make sure that the screwdriver does not touch the scale when applying it to the external setting device.

- Unscrew the external setting device from the cover.

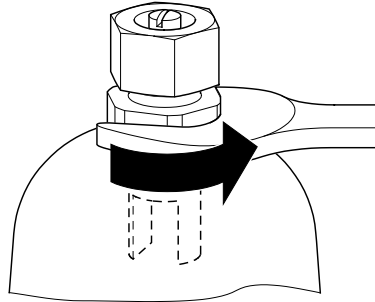

### **Attention!**

Dirt deposits on gasket seating surfaces may result in leaking of the equipment.

- Clean seating surfaces before inserting a new gasket.

### **Attention!**

Equipment may leak if the gasket is damaged.

- It is therefore essential that you always insert a new gasket before re-attaching the external setting device.
- Make sure that the external setting device is not tilted or skewed when refitted.



- Put a new gasket onto the external setting device.
- 

**Attention!**

Equipment may be damaged if the external setting device is tilted or skewed when fitted.

- When screwing the external setting device with the forked adjustment piece onto the square nut of the Thermovit regulator make sure that it is upright and correctly aligned.
- 

- Put the external setting device with the forked adjustment piece (13) over the square nut (4) through the bore of the cover (2). (step 1.)
- 

**Attention!**

Equipment may be damaged if screwdriver is applied to the scale.

Using a screwdriver may cause damage to the scale of equipment type BW 31.

- Make sure that the screwdriver does not touch the scale when applying it to the external setting device.
- 

- Fasten the external setting device with the following tightening torque: (step 2.)

- ▶ DN15 to DN25: 90 Nm
- ▶ DN40: 140 Nm.

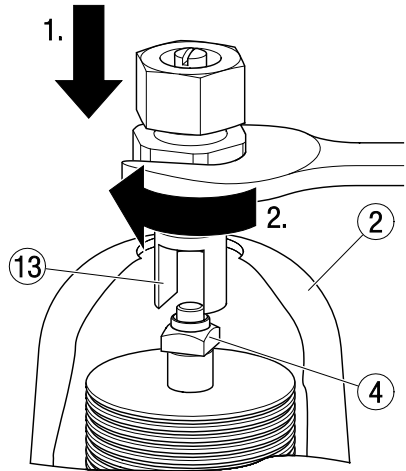

## Troubleshooting

| <b>Fault</b>  | <b>Cause</b>   | <b>Remedy</b>   |
|---|--|---|
| Equipment does not control correctly.                             | The Thermovit regulator is contaminated.   | Remove Thermovit regulator.<br>Rinse equipment.<br>Rinse Thermovit regulator.<br>Mount Thermovit regulator. |
|   | The Thermovit regulator is damaged.  | Discard and replace Thermovit regulator.  |
| The outlet temperature exceeds the adjusted closing temperature.  | The leak passage is too high.<br>The design data for sizing the equipment was wrong.                                 | Change the settings of the installation or mount correctly sized equipment.                                 |
| The intended flowrate or the service temperature are not reached. | The design data for sizing the equipment was wrong.<br>The settings of the installation differ from the design data. |   |

- If faults occur that are not listed above or cannot be corrected, please contact our Technical Service or authorized agency in your country.

## Putting equipment out of operation

### Removing harmful substances



#### **DANGER**

If the equipment is used in contaminated areas there is a risk of severe injuries or death caused by harmful substances in or on the equipment.

- Only qualified personnel are allowed to perform work on contaminated equipment.
- Always wear the protective clothing prescribed for contaminated areas when working on the equipment.
- Make sure that the equipment is completely decontaminated before carrying out any service work.
- Follow the pertinent instructions for handling the hazardous substances in question.

Qualified personnel must have extensive experience with and a working knowledge of:

- ▶ pertinent rules and regulations concerning handling hazardous substances
- ▶ special regulations for handling the hazardous substances encountered on site
- ▶ using the required personal protective equipment (PPE) and clothing

#### **Attention!**

Environmental damage may be caused by poisonous fluid residues.

- Before disposing of the equipment make sure that it is clean and free of fluid residues.
- For the disposal of all materials observe the pertinent legal regulations concerning waste disposal.

- Remove all residues from the equipment.
- For the disposal of all residues observe the pertinent legal regulations concerning waste disposal.

### Removing equipment



#### **DANGER**

Personnel working on pipes are exposed to safety risks and may suffer severe injuries, burns, poisoning or even loss of life.

- Make sure that no hot or hazardous fluid is in the equipment or the pipes.
- Make sure that the installation is switched off and protected against unauthorised or unintended activation.
- Make sure that the equipment and the pipes have cooled down to room temperatures.



#### **CAUTION**

Danger of bruising if the equipment falls down.

- When removing the equipment make sure the it is safely held in place and cannot fall down.

Suitable measures are for instance:

- ▶ Equipment that is not too heavy may be supported by a second person.
- ▶ For heavy equipment use suitable lifting equipment of sufficient strength.
- Detach the end connections of the equipment from the pipes.
- Put the equipment onto a suitable base.
- Store the equipment as described in section "Storing the equipment" on page 8.

## Re-using equipment after storage

Observe the following instructions if you want to remove the equipment and use it again somewhere else:

- ▶ Make sure that the equipment is free of any fluid residues.
- ▶ Make sure that all connections are in good condition and leak-free.
- ▶ If necessary re-work welded connections in order to ensure that they are in good working condition.
- Use the equipment only for its intended purpose and the service conditions for which it was specified.

## Disposing of equipment

### **Attention!**

Environmental damage may be caused by poisonous fluid residues.

- Before disposing of the equipment make sure that it is clean and free of fluid residues.
- For the disposal of all materials observe the pertinent legal regulations concerning waste disposal.

The equipment is made from the following materials:

| Component  | EN              | ASTM        |
|--|-----------------|-------------|
| Body   | 1.0460          | A 105       |
| Cover  |                 |             |
| Body screws  | 1.7225          | A 193 B7    |
| Thermovit regulator                                | Stainless steel |             |
| Body gasket  | Graphite / CrNi |             |
| External setting device BW31                       | CW 612 N        | –           |
| Seal ring for external setting device BW31         | EPDM            |             |
| Gasket for external setting device BW31 and BW 31A | 1.4301 N        | –           |
| External setting device BW31A                      | 1.4571          | AISI 316 Ti |
| Stuffing box BW31A                                 | Graphite        |             |

## Technical data

### Dimensions and weights

#### BW 31

|                              | Flanges to EN PN40* |     |     |     | Flanges to ASME Class 150/Class 300 |     |     |           | Screwed sockets, socket-weld ends |    |     |    | Butt-weld ends via transition pieces |    |     |    |
|------------------------------|---------------------|-----|-----|-----|-------------------------------------|-----|-----|-----------|-----------------------------------|----|-----|----|--------------------------------------|----|-----|----|
|                              | 15                  | 20  | 25  | 40  | 15                                  | 20  | 25  | 40        | 15                                | 20 | 25  | 40 | 15                                   | 20 | 25  | 40 |
| Nominal size DN              | 15                  | 20  | 25  | 40  | 15                                  | 20  | 25  | 40        | 15                                | 20 | 25  | 40 | 15                                   | 20 | 25  | 40 |
| Overall length [mm]          | 150                 |     | 160 | 200 | 150                                 |     | 160 | 216/230** | 95                                |    | 130 |    | 200                                  |    |     |    |
| Height without ESD*** [mm]   | 128                 |     | 188 |     | 128                                 |     | 188 |           | 128                               |    | 188 |    | 128                                  |    | 188 |    |
| Height with ESD*** [mm]      | 187                 |     | 248 |     | 187                                 |     | 248 |           | 187                               |    | 248 |    | 187                                  |    | 248 |    |
| Space required for servicing | 110                 |     | 70  |     | 110                                 |     | 70  |           | 110                               |    | 70  |    | 110                                  |    | 70  |    |
| Width of cover flange[mm]    | 85                  |     | 115 |     | 85                                  |     | 115 |           | 85                                |    | 115 |    | 85                                   |    | 115 |    |
| Weight [kg]                  | 4.4                 | 5.3 | 5.7 | 12  | 4.4                                 | 5.3 | 5.7 | 12        | 2.4                               |    | 8.0 |    | 2.9                                  |    | 8.5 |    |

\* DN40: PN25

\*\* Class 300: 230 mm

\*\*\* External setting device

#### BW 31A

|                              | Flanges to EN PN40* |     |     |     | Flanges to ASME Class 150/Class 300 |     |     |            | Screwed sockets, socket-weld ends |    |     |    | Butt-weld ends via transition pieces |    |     |    |
|------------------------------|---------------------|-----|-----|-----|-------------------------------------|-----|-----|------------|-----------------------------------|----|-----|----|--------------------------------------|----|-----|----|
|                              | 15                  | 20  | 25  | 40  | 15                                  | 20  | 25  | 40         | 15                                | 20 | 25  | 40 | 15                                   | 20 | 25  | 40 |
| Nominal size DN              | 15                  | 20  | 25  | 40  | 15                                  | 20  | 25  | 40         | 15                                | 20 | 25  | 40 | 15                                   | 20 | 25  | 40 |
| Overall length [mm]          | 150                 |     | 160 | 200 | 150                                 |     | 160 | 216/230*** | 95                                |    | 130 |    | 200                                  |    | 250 |    |
| Height without ESD*** [mm]   | 128                 |     | 188 |     | 128                                 |     | 188 |            | 128                               |    | 188 |    | 128                                  |    | 188 |    |
| Height with ESD*** [mm]      | 150                 |     | 235 |     | 150                                 |     | 235 |            | 150                               |    | 235 |    | 150                                  |    | 235 |    |
| Space required for servicing | 110                 |     | 70  |     | 110                                 |     | 70  |            | 110                               |    | 70  |    | 110                                  |    | 70  |    |
| Width of cover flange[mm]    | 85                  |     | 115 |     | 85                                  |     | 115 |            | 85                                |    | 115 |    | 85                                   |    | 115 |    |
| Weight [kg]                  | 4.4                 | 5.3 | 5.7 | 12  | 4.4                                 | 5.3 | 5.7 | 12         | 2.4                               |    | 8.0 |    | 2.9                                  |    | 8.5 |    |

\* DN40: PN25

\*\* Class 300: 230 mm

\*\*\* External setting device

## Pressure & temperature ratings

### Pressure & temperature ratings for DN15, DN20, DN25

Max. differential pressure delta PMX: 6 bar

| <b>End connection</b>    | <b>Flanges to EN PN40</b>        |      |      |      |      |      |
|--------------------------|----------------------------------|------|------|------|------|------|
| Service pressure [barg]  | 40.0                             | 37.1 | 33.3 | 27.6 | 25.7 | 23.8 |
| Inlet temperature [°C]   | -10/20                           | 100  | 200  | 300  | 350  | 400  |
| <b>End connection</b>    | <b>Flanges to ASME Class 150</b> |      |      |      |      |      |
| Service pressure [barg]  | 19.6                             | 17.7 | 13.8 | 10.2 | 8.4  | 6.5  |
| Inlet temperature [°C]   | -29/38                           | 100  | 200  | 300  | 350  | 400  |
| <b>Anschlussart</b>      | <b>Flanges to ASME Class 300</b> |      |      |      |      |      |
| Betriebsüberdruck [bar]  | 51.1                             | 46.6 | 43.8 | 39.8 | 37.6 | 34.7 |
| Eintrittstemperatur [°C] | -29/38                           | 100  | 200  | 300  | 350  | 400  |

### Pressure & temperature ratings for DN 40

Max. differential pressure delta PMX: 6 bar

| <b>End connection</b>   | <b>Flanges to EN PN25</b>        |      |      |      |     |      |
|-------------------------|----------------------------------|------|------|------|-----|------|
| Service pressure [barg] | 25.0                             | 23.2 | 20.8 | 17.2 | –   | 14.8 |
| Inlet temperature [°C]  | -10/20                           | 100  | 200  | 300  | –   | 400  |
| <b>End connection</b>   | <b>Flanges to ASME Class 150</b> |      |      |      |     |      |
| Service pressure [barg] | 19.6                             | 17.7 | 13.8 | 10.2 | 8.4 | 6.5  |
| Inlet temperature [°C]  | -29/38                           | 100  | 200  | 300  | 350 | 400  |

## Closing temperatures

|   | <b>Adjustable closing temperatures [°C]</b> |                       |                      |                      |
|---|---|-----------------------|----------------------|----------------------|
|   | <b>DN15<br/>0.5"</b>                        | <b>DN20<br/>0.75"</b> | <b>DN25<br/>1.0"</b> | <b>DN40<br/>1.5"</b> |
| BW 31                                       | 60–130                                      | 40–115                |                      | 50–110               |
| BW 31 with external setting device          | 60–130                                      | 40–115                |                      | 50–110               |
| BW 31 with special external setting device  | 20–110                                      | 20–90                 |                      | 20–75                |
| BW 31A, BW 31A with external setting device | 90–270                                      | 70–270                |                      |                      |
| BW 31A with special external setting device | 60–160                                      | 30–170                |                      | 25–85                |

## Manufacturer's Declaration

For more information on the Conformity Assessment according to European rules refer to our Declaration of Conformity or our Declaration by Manufacturer.

To download the current Declaration of Conformity or Declaration by Manufacturer go to [www.gestra.com/documents](http://www.gestra.com/documents) or contact:

### **GESTRA AG**

Münchener Straße 77

28215 Bremen

Germany

Telefon +49 421 3503-0

Telefax +49 421 3503-393

E-Mail [info@de.gestra.com](mailto:info@de.gestra.com)

Web [www.gestra.de](http://www.gestra.de)

This declaration is no longer valid if modifications are made to the equipment without consultation with us.



Agencies all over the world:

## **GESTRA AG**

Münchener Straße 77

28215 Bremen

Germany

Telefon +49 421 3503-0

Telefax +49 421 3503-393

E-Mail [info@de.gestra.com](mailto:info@de.gestra.com)

Web [www.gestra.de](http://www.gestra.de)

819026-01/07-2017 kx\_mm (808784-01) © GESTRA AG Bremen Printed in Germany